

# siste masde brazos

**Gran versatilidad**  
Great versatility  
Grande polyvalence  
Sehr vielseitig

## Brazo Stor



## Características y aplicaciones



Sistema con aplicación principal en balcones con techo, con brazos de 50 cm. montados en el tubo de carga y con fijación sobre la baranda del balcón mediante una pieza que permite dos tipos de sujeción:

- a) Toldo. (Inclinación).
- b) Telón. (Vertical).

## Characteristics and applications



System designed to be used in balcony with ceiling, with 50 cm. arms assembled on the head bar and hooked up to the rail through a component permitting a double subjection:

- a) Awning. (Sloped).
- b) Blind. (Vertical).

## Caractéristiques et les usages



Système s'appliquant principalement sur balcon avec toit, avec bras de 50 cm. montés sur le tube porteur et avec fixation sur la balustrade du balcon au moyen d'une pièce qui permet deux types de fixation :

- a) Store. (Inclinaison).
- b) Toile. (Verticale).

## Eigenschaften und Anwendungen



System hauptsächlich für Balkone mit Dachvorsprung, mit an der Fallstange montierten Armen von 50 cm und zwei Befestigungen am Geländer des Balkons:

- a) Markise. (Neigung).
- b) Vorhang. (Vertikal).

## Brazo Stor

Despiece - Stor Arm parts - Pièces de Bras Stor - Komponenten der Arm Stor

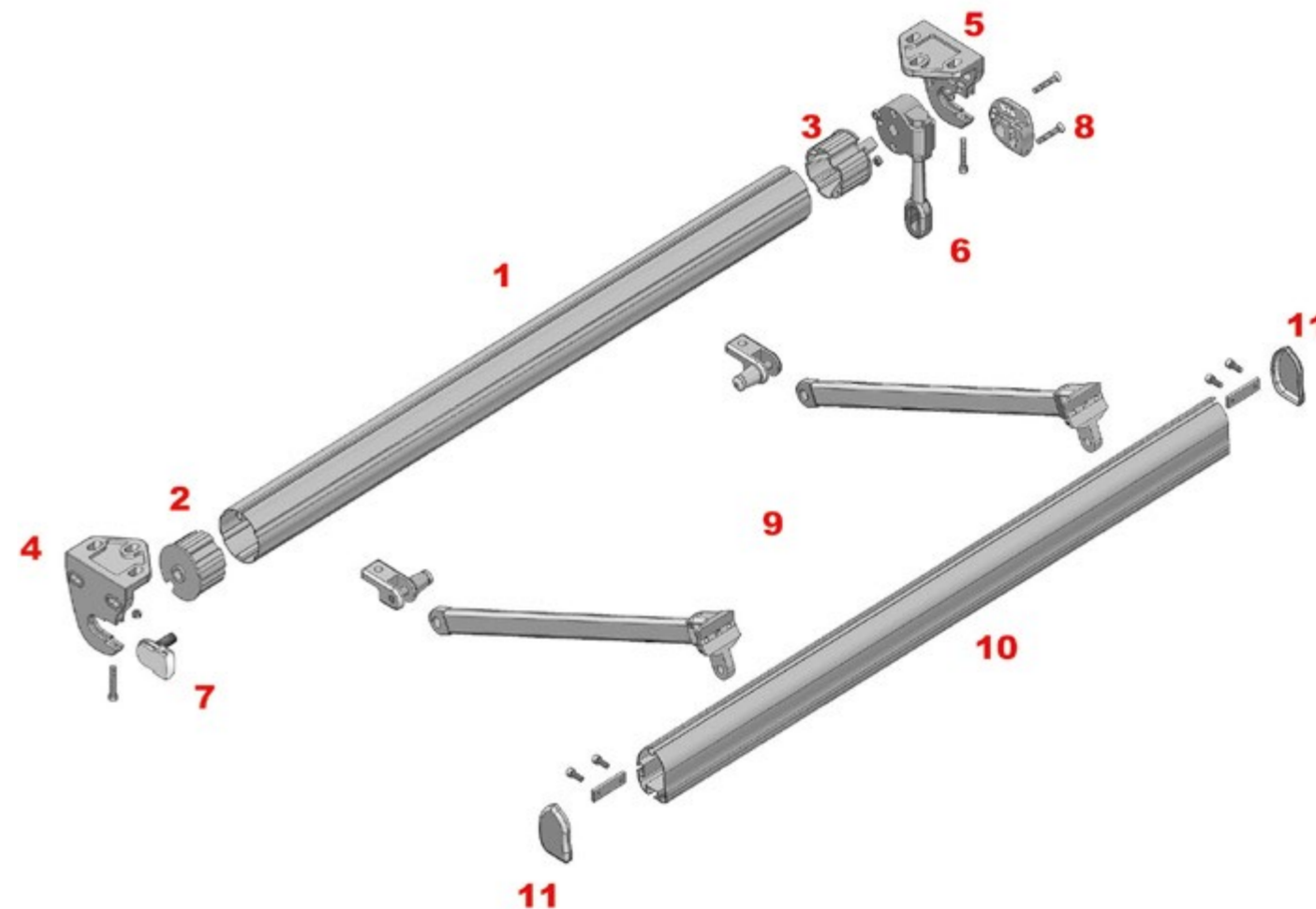

- 1: Tubo de enrolla
- 2: Casquillo sin punta
- 3: Casquillo punta máquina
- 4: Soporte jaraba izquierdo
- 5: Soporte jaraba derecho
- 6: Máquina
- 7: Acople punta
- 8: Acople máquina
- 9: Juego brazos stor
- 10: Perfil carga cazorla
- 11: Tapones perfil de carga



- 1: Rolling tube
- 2: Valve holder without point
- 3: Point Machine valve holder
- 4: Left Jaraba support
- 5: Right Jaraba support
- 6: Machine
- 7: Point coupling
- 8: Machine coupling
- 9: Stor arms kit
- 10: Cazorla Load profile
- 11: Load profile plugs



- 1: Tube d'enroulement
- 2: Douille sans axe
- 3: Douille machine pointe
- 4: Support jaraba gauche
- 5: Support jaraba droit
- 6: Machine
- 7: Raccord pointe
- 8: Raccord machine
- 9: Jeu bras stor
- 10: Profil de charge cazorla
- 11: Cache profil de charge



- 1: Tuchwalze
- 2: Buchse ohne Stift
- 3: Buchse Stift/Maschine
- 4: linker Halter Jaraba
- 5: Rechter Halter Jaraba
- 6: Getriebe
- 7: Ankopplung Stift
- 8: Ankopplung Getriebe
- 9: Armsatz stor
- 10: Fallstange cazorla
- 11: Fallstangelabdeckung



Ref.: 510005\_\_

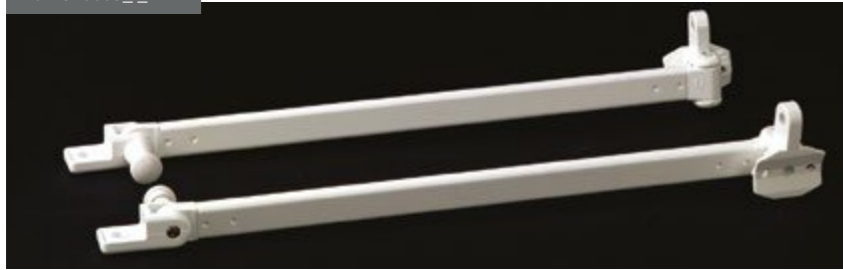

Juego Brazos Stor  
Stor Arm Kit  
Jeu de Bras Stor  
Armsatz Stor

Ref.: 510200\_\_



Juego Enganche Baranda  
Coupling Rail Kit  
Jeu Crochet Balustrade  
Set Befestigung am Geländer

Ref.: 510400\_\_



Juego Herrajes Stor  
Stor Ironwork Kit  
Jeu de Ferrures  
Set Beschläge Stor

Ref.: 510300\_\_



Terminal Inferior Stor  
Stor Lower Terminal  
Terminal Inférieur  
Unteres Fallstange Stor

Ref.: 510100\_\_



Soporte Pared Stor  
Stor Wall Support  
Support Mur Stor  
Wandhalterung Stor

Ref.: 515060\_\_



Perfil Brazo Stor  
Stor Arm Profile  
Profil Stor Arm  
Profil Arm Stor

Ref.: 500100\_\_



Juego Soportes Jaraba  
Jaraba Supports Kit  
Jeu de Supports Jaraba  
Set Jaraba-Halter

Ref.: 717000\_\_



Máquina Siplan 1.7  
1.7 Siplan Machine  
Machine Siplan 1.7  
Getriebe Siplan 1.7

Ref.: 500600\_\_



Juego Soportes Jaraba con Eje Doble  
Jaraba Double Axis Supports Kit  
Jeu de Supports avec Axe Double  
Set Jaraba-Halter mit Doppelachse

Ref.: 501500\_\_



Soporte Jaraba de transmisión  
Transmission Jaraba Support  
Support Jaraba de transmission  
Übertragung Jaraba-Halter

# Brazo Stor

Datos Técnicos - Technical Data - Données Techniques - Technische Daten

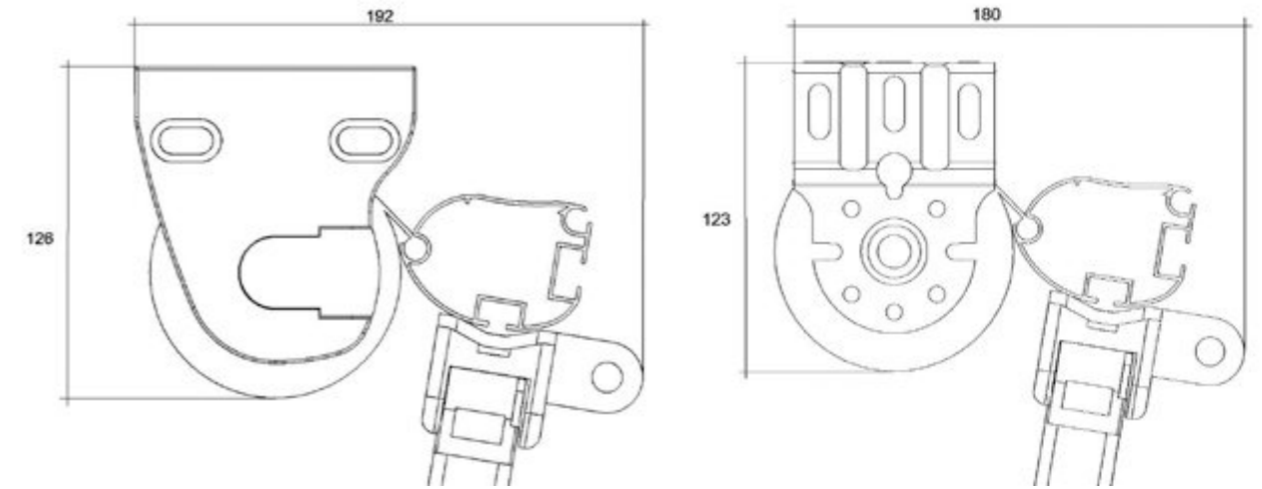

MEDIDAS DEL TUBO DE ENROLLE (no admite holguras) ROLLING TUBE SIZE (not admit roominess) MESURES DU TUBE D'ENROULEMENT (ne supporte pas d'habilitations) MASSE DER TUCHWALZE (ohne Spiel)			
	MÁQUINA 1.7 MACHINE GETRIEBE	MOTOR CON SOPORTE MOTOR WITH SUPPORT MOTEUR AVEC SUPPORT MOTORHALTER	MOTOR SIN SOPORTE MOTOR WITHOUT SUPPORT MOTEUR SANS SUPPORT MOTOR OHNE HALTER
SOPORTE CON EJE SUPPORT WITH AXIS SUPPORT AVEC AXE HALTER MIT ACHSE	LT-70 mm.	LT-60 mm.	LT-50 mm.
SOPORTE JARABA JARABA SUPPORT SUPPORT JARABA HALTER JARABA	LT-90 mm.	LT-80 mm.	LT-70 mm.

NOTA: LT= LÍNEA TOTAL (tapas incluidas)  
NOTE: LT = TOTAL LINE (caps included)  
REMARQUE: LT = TOTAL LIGNE (tapas dont)  
NOTE: LT = Gesamtbreite (inkl. Abdeckungen)